

PRO Technical regulations 2023- LATVIA AND ESTONIA PRO DRIFT CHAMPIONSHIP, LIVONIA PRO DRIFT CHAMPIONSHIP, BALTIC PRO DRIFT CHAMPIONSHIP, NEZ SERIES

1. COMPETITION VEHICLES

- 1.1. Eligible models must be considered a "production vehicle" and have had a minimum build run of 600 units in each model year.
- 1.2. Eligible body styles include: coupe, sedan, convertible or wagon.
- 1.3. Vehicles must maintain the original OEM steel unibody and/or steel frame structure between the OEM front and rear suspension mounting points.
- 1.4. Trucks or SUVs or cars with tubular frame are not allowed.
- 1.5. Vehicles that do not meet the above eligibility criteria must petition for approval from Drift working group.
- 1.6. All changes and modifications what are not allowed here, are forbidden.
- 1.7. All the modifications must be of high quality. The quality of the construction is assessed by the scrutineers.
- 1.8. All additions, modifications and solutions of which by the scrutineers is deemed to be dangerous, is considered dangerous, and the participation of such a car in the race shall be decided by the Clerk of the Course on the basis of a report from the scrutineers
- 1.9. The use and installation of car parts defined as "free" in these rules must comply with FIA Annex J Articles 252 and 253. "Free" means that if the original part is removed and replaced with a new part, the new part must not have any additional functions other than the original working principle.
- 1.10. All cars must be equipped with competition numbers and advertising stickers prescribed by the competition manual. It is forbidden to install stickers on the contact points of the doors, hood and side panels. Advertising on the car must not obstruct the field of view of the competitor.

2. CHASSIS

CHASSIS MODIFICATIONS

- 2.1. The original OEM floorpan, frame and or unibody must remain unmodified between the vertical planes created by the original forward most and rear ward most suspension point or subframe mounting point. Picture 1.
- 2.2. Unibody or chassis may be stitch or seam welded.
- 2.3. Plating (strengthening) of chassis floor is prohibited.

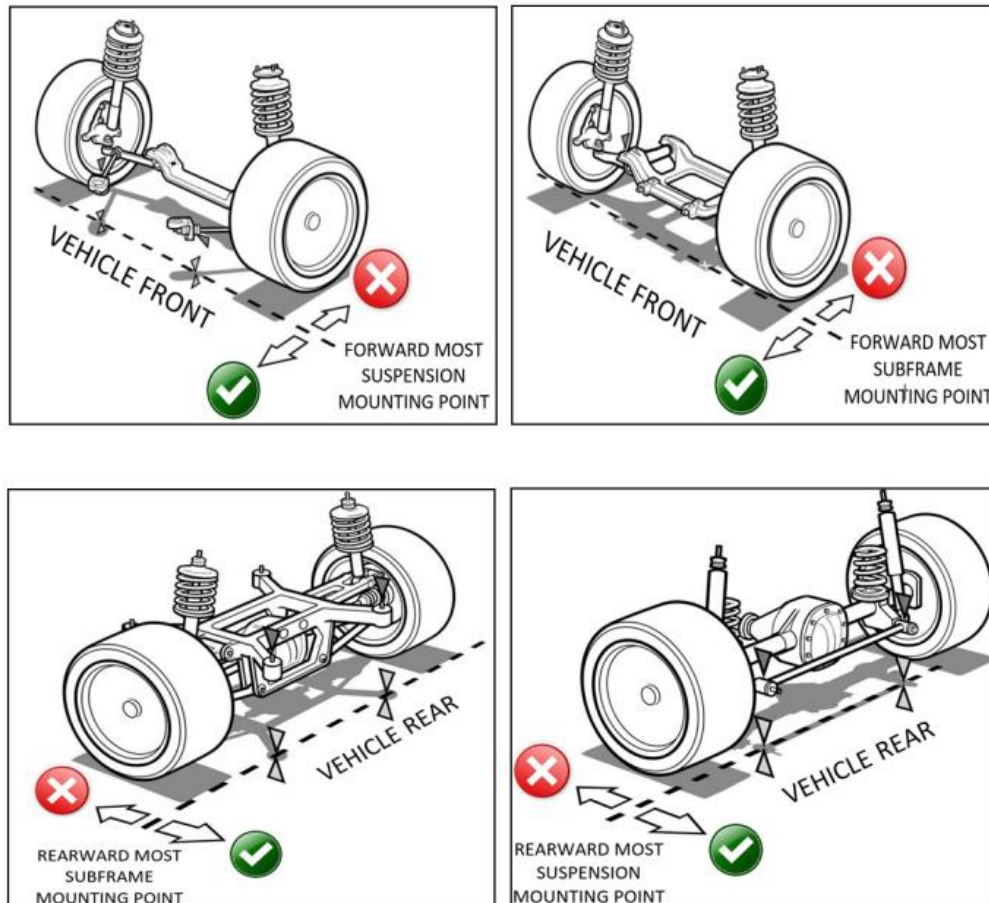

- 2.4. The original OEM floorpan, frame and or unibody must remain unmodified between the horizontal planes, created by the original floorpan, at the lowest horizontal plane to the roof, at its highest horizontal plane. With the exception of transmission, tunnel and firewall dimensions listed below and Fuel cell rule and running gear rule.
- 2.5. Items in the unmodified zone that are allowed to be removed can include original rear window parcel shelf, tabs or mounts for unused OEM steering columns, unused OEM windshield wiper mounts, and the exterior roof panel can be replaced with a composite panel. Cutting and modifying outer shell is allowed for installing aftermarket body panels. Any modifications to B pillar is not allowed.

- 2.6. Rear suspension tower cross-members, located at the top of the rear suspension towers may be removed from the unibody interior only if a suitable replacement structure of equivalent strength is installed.
- 2.7. No part of the engine casing may cross the vertical threshold of the original firewall into the transmission tunnel.
- 2.8. No other modifications can do to the vehicle chassis, frame, or unibody.
- 2.9. Any holes in the firewall must be of the minimum size for the passage of controls and wires, and must be completely sealed, to prevent the passage of fluids or flames from the engine compartment to the driver's compartment.

3. FIREWALL AND TRANSMISSION TUNNEL

- 3.1. Modifications of the stock, OEM firewall and transmission tunnel are in Picture 2:

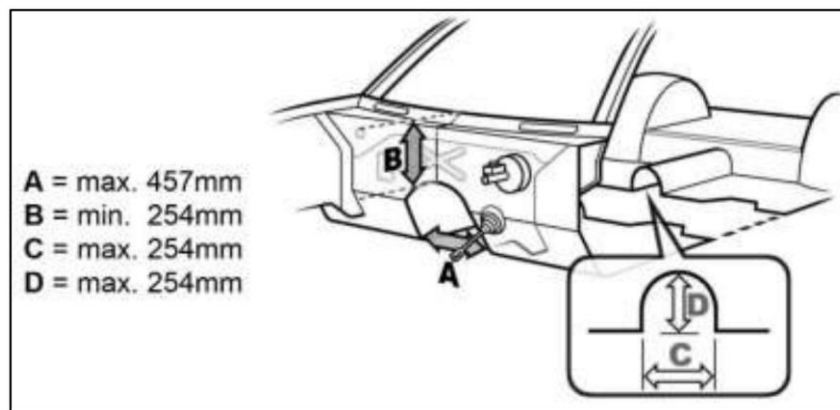

Picture 2

- 3.2. Dimension A: Tunnel Width may be no wider than 45,70cm
- 3.3. Dimension B: Minimum dimension of 25,4cm between the bottom of the windshield and the top of the transmission tunnel.
- 3.4. Dimension C: Modifications to drive shaft tunnels behind the engine firewall vertical plane should not exceed an overall width of 25,4cm.
- 3.5. Dimension D: Modifications to drive shaft tunnels behind the engine firewall vertical plane should not exceed an overall width of 25,4cm.
- 3.6. Taper Length from the firewall to the end of the transmission tunnel into the beginning of the drive shaft hump may be no longer than 91,45cm.

4. ROLLAGE- SAFETY CAGE

- 4.1. Pro class cars must have a safety cage installed.
- 4.2. The fitting of safety cage according to FIA Appendix J Art. 253.8 is compulsory for cars with EASU technical card.

- 4.3. Cars made from 2018 –must be in accordance with Annex "J" 253 FIA ART 8.
- 4.4. For safety cages of cars homologated before 31.12.2017, refer to Articles 253-8 of the 2016 Appendix J.
- 4.5. Any cage, which is homologated by an ASN, must be identified by means of an identification plate affixed to it by the manufacturer this identification plate, must be neither copied nor moved (i.e. embedded, engraved, metallic plate). The identification plate must bear the name of the manufacturer, the homologation or certification number of the ASN homologation formor certificate and the individual series number of the manufacturer. An authentic copy of the homologation document or certificate bearing the same numbers, approved by the ASN and signed by qualified technicians representing the manufacturer, must presented to the competition's scrutineers.
- 4.6. Allowed only seam-welded rollcages.
- 4.7. Teams may also choose to install “NASCAR-STYLE” bars and extend into the outer door skin. In this configuration, the outer bars must also have a minimum of three vertical tube sections connecting the upper and lower bars. According to FIA Appendix J article 269 DC1 regulations. Picture 3.

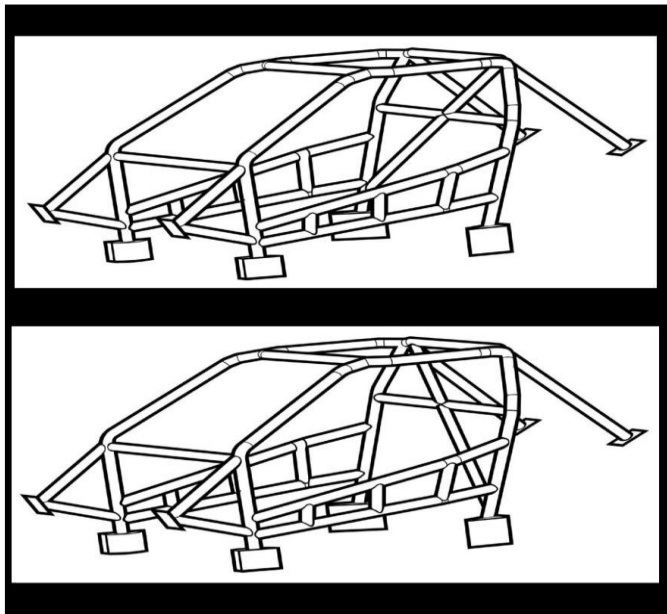

5. PADDING

- 5.1. Padding must meet spec FIA 8857-2001.
- 5.2. Where the occupants' bodies could come into contact with the safety cage, flame retardant padding must be provided for protection. All tubes of the cage identified on Drawing 253-68 and all roof reinforcements must be fitted with paddings in complian-ce with FIA standard. Drawing 3

5.3. 8857-2001 type A (see Technical List n°23). Each padding must be fixed in such a way that it is not moveable from the tube. If only 1 racing seat is used, padding must be used according to picture 2 RHD and opposite for LHD

5.4. Safety cage tubes less than 40 cm from the head of the drivers must also be covered with flame retardant paddings

5.5. Padding is required anywhere driver helmet may come in contact with the roll cage and along the base of the driver's side A-pillar bar and box if applicable. Picture 4.

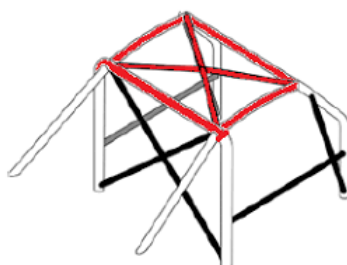

6. BUMPERS

- 6.1. All vehicles must be equipped with safe front and rear bumpers.
- 6.2. Bumpers at minimum must span the width of the front and rear frame rails.
- 6.3. Bumper bars must remain in the confines of the bodylines and bodywork, without additional covers or bodywork extensions in order to do so.
- 6.4. Bumpers must be attached to the vehicle by means of 2, for example 8 mm welded bolts, on the side with a minimum hardness class 8.8, in order to prevent the bumper from falling off the vehicle .
- 6.5. The construction of the bumper must not protrude beyond the outline of the car and must be completely under the outer bumper.

7. SUSPENSION AND BRAKES

FRONT SUSPENSION

- 7.1. Free modification
- 7.2. OEM front sub-frames and cross members are recommended
- 7.3. It is allowed to use manufacturer specific front subframes from other same manufacturer models.
- 7.4. Modified or aftermarket suspension parts, including hubs, are allowed.
- 7.5. All original suspension mounting tabs must remain in the original position.

7.6. Its allowed to use secondary rear brake calipers, they can be only bolted on brackets and brackets bolted to trailing arm, no welding allowed.

STEERING

7.7. Modifications of steering components (steering rack, tie rods, etc) are free.

7.8. This includes mounting the rack to the front subframe.

7.9. The locking system of the anti-theft steering lock must be rendered inoperative.

7.10. The column adjusting system must be locked and must be operated only with tools.

7.11. The power steering tank must be ventilated. Ventilation of the power steering tank must be installed in a secure container fitted with a breather filter element for discharging pressure into the atmosphere.

REAR SUSPENSION LIVE AXLE

7.12. Free modifications

7.13. The original chassis mounting points must remain unaltered and in the original factory position.

7.14. Suspension relocation brackets that move suspension points or pivots regardless of if they are bolt into the chassis will not be allowed.

7.15. Original suspension design must remain

REAR SUSPENSION – INDEPENDENT

7.16. Free modifications

7.17. The original chassis mounting points must remain unaltered and in the original factory position.

7.18. OEM rear sub-frames and cross members are recommended

7.19. It is allowed to use manufacturer specific rear subframes from other same manufacturer models.

7.20. Modified or aftermarket suspension parts, including hubs, are allowed.

7.21. Additional mounting tabs may be added to the subframe relocate the suspension arm mounting points a maximum of 50mm on any plane from the original mounting position.

7.22. The rear subframe may be modified to install or relocate the differential, but at least one of the main beams of the rear subframe must remain fully intact.

BRAKES

7.23. The primary brake system must operate all four wheels.

7.24. Dual master cylinders pedal assemblies are allowed.

7.25. Driver adjustable brake bias is allowed.

- 7.26. Secondary hydraulic e-brake systems are allowed as a fully separate system or as a pass through system.
- 7.27. Carbon fiber, carbon ceramic, and carbon variant brakes or rotors are not allowed.
- 7.28. Brake pedal box reservoirs must be outside the cockpit or closed version or located in a sealed container.
- 7.29. Handbrake reservoir should be closed one.
- 7.30. Brake shut-off valve is prohibited.

WHEELS

- 7.31. The use of additional locks between the rim and the tire is forbidden.
- 7.32. The size of the wheels is free.
- 7.33. Wheels must be in contrasting color or have different color stickers on each rim. Wheel rim stickers must be a minimum of 2,5x10cm

8. DRIVETRAIN

ENGINE

- 8.1. Engine substitutions and modifications are free, but may only run on gasoline, diesel, and ethanol blends.
- 8.2. All fluid systems must be free of leaks.

ENGINE CRANKCASE VENTILATION

- 8.3. Engine crankcase ventilation should be maintained in its original performance. If the engine air intake system is changed from the original, engine crankcase ventilation must be entered into securely secured container with a breather filter element for discharging pressure into the atmosphere.

COOLING SYSTEM

- 8.4. Cooling system modifications are free but must be fully closed and free of leaks.
- 8.5. Automatic water sprayers will be allowed during competition, but must not be leaking on the track, starting line, or grid area.
- 8.6. If cooling system lines are routed in the driver's compartment or a trunk area that is open to the driver, they must be separated from the driver by a crushable metal enclosure made of steel, aluminium or composite material. The floor of the enclosure must be designed to prevent accumulation of fluids. Liquids must not spray out of the housing if the cooling system lines break.
- 8.7. Cooling systems shall be filled with water only. Coolant Additives such as NEO "Keep Cool" and Redline "Water Wetter" are allowed.

OIL SYSTEM

- 8.8. Oil system modifications are free but must be fully closed and free of leaks.
- 8.9. If the oil tank is located in the driver's compartment area, or a trunk area that is open to the driver, it must be separated from the driver by a metal enclosure made up steel or aluminium
- 8.10. The floor of the enclosure must be designed to prevent accumulation of fluids.
- 8.11. Engine crankcase ventilation must be entered into securely secured container with a breather filter element for discharging pressure into the atmosphere. We recommend using Half Engine size containers. (E.g., If engine is 2.0L then container should be 1L) Container should not be bigger than 3L.

FUEL SYSTEM

- 8.12. Fuel tank. Original fuel tank can be replaced with FIA FT3 1999, FT 3,5; FT5 với SFI Spec 28.1, 28.2, 28.3, 32.1 safety fuel tank or other fuel tanks specified for autosport. Such fuel tanks must be labelled with:
- name of the manufacturer
 - model and the serial number
 - manufacturing or expiring date

If these data are not available, the fuel tank must be submitted to the Technical Commission before installation in the car in order to receive the required marking.

- 8.13. The fuel system design is free, but engines may only run on gasoline, diesel, and ethanol blends. Cars running bioethanol E85 should be with equipped with E85 sticker on it. Picture 5.



- 8.14. Safety Fuel cells are required for all vehicles with a relocated fuel tank. FT3-1999, FT3.5-1999 or FT5-1999 and SFI 28.1 are accepted. They can be used with ended homologation term.
- 8.15. The use of safety foam in FT3-1999, FT3.5-1999 or FT5-1999 tanks is recommended.
- 8.16. Safety fuel cells shall consist of a bladder enclosed in a metal container.
- 8.17. If the factory fuel tank is retained it must mounted in the factory location, and in the factory manner.
- 8.18. Fuel tank/cell must be separated, and completely sealed, to prevent the passage of fluid, or flames, from entering the driver's compartment by a permanently mounted steel, or aluminium bulkhead. The bulkhead in a hatchback vehicle must be affixed to the chassis and no

movable structure or panel such as the hatch will be allowed as part of the bulkhead. Fuel cells may be installed in the interior of the vehicle, preferably within the confines of the roll cage structure.

- 8.19. The floor pan may be modified to fit a fuel cell.
- 8.20. Fuel cells must have a flapper valve installed to prevent spillage in the event of a roll over.
- 8.21. Fuel System must not leak on the track, starting line, or grid area.
- 8.22. Fuel cell ventilation must be entered into safety rollover 2way ventilation valve.

FUEL LINES

- 8.23. Fuel lines and fittings according FIA appendix J 253 Art 3.
- 8.24. All the fuel pumps must only operate when the engine is running, except during the starting process.

EXHAUST SYSTEM

- 8.25. Exhausts are free to exit from. They must be adequately silenced and not be louder than 100dB (A) at 4500rpm.
- 8.26. The noise level must not exceed 100 dB + 5% at 4500rpm, measured at a distance of 0,5m from the end of the silencer at an angle of 45 degrees at 4500rpm in "A" and "SLOW" mode.
- 8.27. The tip of the exhaust pipe must extend over the rear axle and point downwards at a 45-degree angle.
- 8.28. Exhaust system modifications are free, but must past the rear axle or in the original location. (from 2021)
- 8.29. Vehicles must have optional noise bungs, which can be securely installed to comply with additional noise restrictions at each venue. You MUST have options to silence your car at all venues.
- 8.30. If exhaust ends in engine front, cross has to be installed (welded into it).
- 8.31. External wastegates recommended to route back in exhaust system.

STARTER

- 8.32. All vehicles must be equipped with an on-board starter and power, supply that must be in working order at all times.
- 8.33. The racing car engine must start with the starter at any time.

TRANSMISSION

- 8.34. All vehicles must be equipped with a functioning reverse gear.
- 8.35. Transmission and/or final drive modifications are free, but only the rear wheels may propel the vehicle.

8.36. Gearbox and differential ventilation must be entered into securely secured container (outside driver's compartment) with a breather filter element for discharging pressure into the atmosphere.

DRIVESHAFT

8.37. All vehicles must have a driveshaft retaining loop mounted within 15 cm of the forward most universal joint and be securely attached to a unibody or frame structure as in Picture 7.

8.38. The driveshaft loop may be made of minimum 6 x 50mm wide steel strap or 22 x 1,5mm steel tubing and be securely mounted in case of universal joint failure.

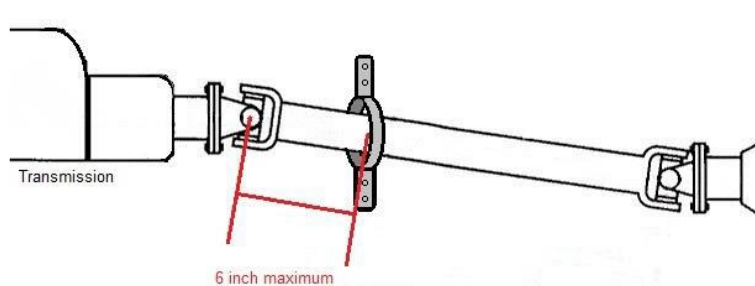

Picture 7

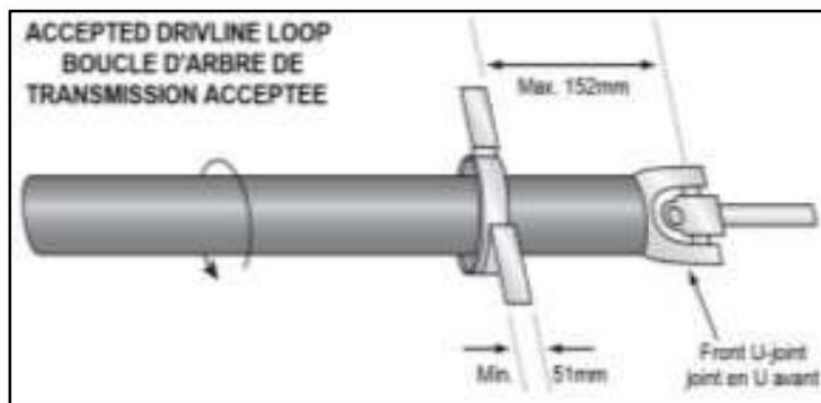

9. VENTILATIONS

The ventilations of the car's equipment (engine, gearbox, differential, power steering) can all be placed in one container, or different containers can also be used. Vent containers must not be located in the driver's compartment and must be equipped with a vent filter to vent pressure to the atmosphere.

10. ELECTRICAL SYSTEM

WIRES

All wire harness, that are located close to exhaust or turbocharger has to be secured with heat resistant, fireproof material. Other wire harness is not regulated, unless they match original and are well secured. Between the roll cage and the body there must not be any wires.

BATTERY

- 11.1. The battery is free, the rated voltage must be maintained.
- 11.2. The battery must be securely mounted and the positive terminal completely insulated to avoid contact with any other metal parts.
- 11.3. Batteries may be relocated.
- 11.4. Relocated batteries must be fastened to the frame or unibody with a minimum of two M10 diameter bolts.
- 11.5. Batteries must be fastened to the frame or unibody with a minimum of two M10 diameter bolts and under each bolt, a counterplate at least 3 mm thick and with a surface of at least 20 cm² beneath the metal of the bodywork.
- 11.6. J bolts or hooks are prohibited. Only metal straps are allowed.
- 11.7. The wet battery must be covered with a leak-proof plastic box, attached independently of the battery. The location of the battery is free, but if in the passenger compartment, then only behind the first seats. If it is a wet battery, the protective box must contain an air inlet with an outlet outside the passenger compartment (see Picture 8). If there is a dry battery in the passenger compartment, it must be electrically protected by a cover that completely covers it.
- 11.8. Only a dry battery may be used in the driver's compartment.

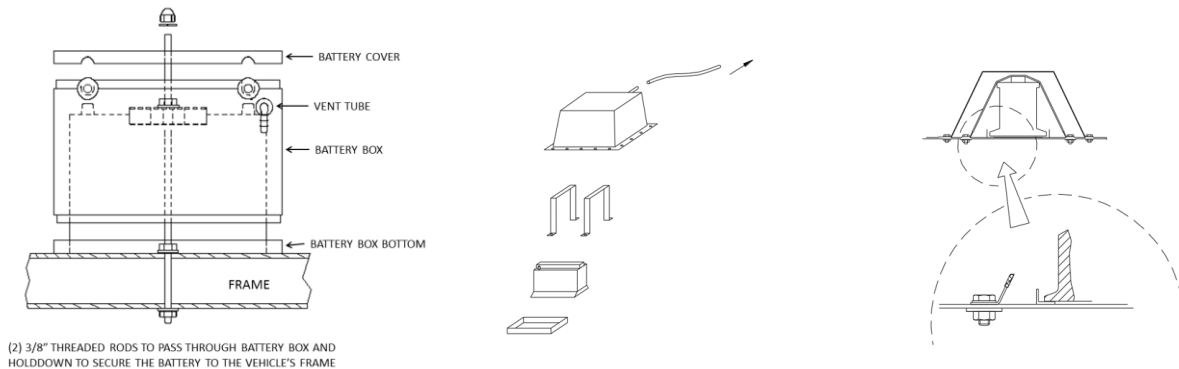

MASTER CUTOFF

- 1.11. The car must be equipped with a general circuit breaker. The general circuit breaker must cut all electrical circuits (battery, alternator or dynamo, lights, hooters, ignition, electrical controls, etc.) and must stop the engine. It must be installed according to the specifications listed in the Appendix J– Art. 253, clause 13 of FIA technical regulations. The location of the master cutoff switch must be marked with a sticker (Picture 9)



11. BODY EXTERIOR AND INTERIOR

BODY PANELS

- Vehicles must maintain the OEM look and feel.
- Panels must be clean, free of damage and presentable for competition.
- All bodywork must be painted or covered and securely attached to the vehicle.
- Aftermarket body panels, front and/or rear fascias, side skirts and wings are permitted.
- Over fenders are allowed.
- All aftermarket panels and aerodynamic devices must be securely fasten to the vehicle.
- It's not allowed to use self thread screws to attach body elements/panels.

DOORS

- Doors must be mounted to the chassis with unmodified factory hinges.
- Doors must use the factory latch mechanism
- The inside and outside door latch/ lock operating mechanism must be functional and readily accessible for the driver to exit the vehicle.
- Composite material doors can be used.

WINDOWS

- Windshields must be OEM glass or Lexan/polycarbonate replacement.
- Lexan/polycarbonate windshields must be a minimum thickness of 5mm. Lexan/polycarbonate windshields must be securely mounted and have a vertical brace which is securely mounted down the center of the opening on inside the vehicle.
- There must be no cracks on the windshield, in the driver's field of vision.
- Windshields must be clear, use of tint is prohibited.
- Lexan/polycarbonate windshields must be securely mounted and have a vertical brace which is securely mounted down the centre of the opening on inside the vehicle.
- Windshields must be clear, use of tint, is prohibited.
- Vehicles must have at least one a functioning windshield wiper on driver's side
- Door, quarter and rear window must be OEM glass or clear/polycarbonate with minimum thickness of 3mm and securely bolted in place.
- Side windows shall have a window net, OEM glass, or a piece of Lexan/polycarbonate in place of both front window openings whenever the vehicle is on-track.
- Side windows and rear windows, use of tint or wrap is prohibited.
- Competitors may choose to use arm restraints in lieu of side windows or a window net.
- Competitors with convertible vehicles must use arm restraints.

- The use of transparent and colourless anti-shatter films (maximum thickness: 100 microns) is compulsory on side and rear windows, unless they are in polycarbonate.

WIPERS

- Vehicles must have a functioning windshield wiper.

MIRRORS

- Two external, rear-facing mirrors are required, and must be positioned so that the driver can see objects along both sides of the vehicle.
- OEM mounting position are encouraged.
- Cameras may be used instead of mirrors.

HOOD PINS

- Composite or fiber materials hood and boot are allowed
- At least two additional safety fasteners must be fitted for each of the bonnet and boot lids.
- The original locking mechanisms must be rendered inoperative or removed.
- Hood must cover all engine bay and must be fixed in 4 attachment points.

TOW STRAP

11.1. The towing straps must be must be at the front and rear of the vehicle.

11.2. Load Rating of not less than the gross vehicle weight.

11.3. The towing strap and its attachment must withstand a pulling force of at least 1.5 tons. If the unladen weight of the vehicle is greater than 1.5 tons, the towing strap and its attachment must withstand at least a pulling force equal to the unladen weight of the vehicle.

- Minimum internal hole diameter of 50mm.
- Coloured in a contrasting colour to the surrounding bodywork.
- If not clearly visible must that their position clearly indicated by the word "TOW" or an arrow in a contrasting body colour.
- If made of a metal it must not protrude from a blunt surface.
- The towing strap can extend a maximum of 50mm out of the body lines.

LIGHTS

- Usage of car manufacturer OEM lights are highly recommended.
- Lights must remain OEM look.
- Brake lights and taillights, may only be red, tinting is prohibited.
- Rear external lights, may be removed, provided that any resultant openings in the
- bodywork are covered. Covers must conform to the original general silhouette.
- LED strips can be used instead of bulbs.

11.4. The original lights can be removed, but the resulting openings in the body must be covered. The hatch covers must follow the body design. A hole of up to 30 cm² can be left in each cover for cooling.

11.5. When removing the original taillights, at least two working brake lights must be added to the car.

11.6. Brake and tail lights can only be red, tinting is prohibited. All rear lights must be located symmetrically with respect to the longitudinal axis of the car and in the same transverse plane.

11.7. It is mandatory to use an additional LED brake light on the rear window. The minimum length of the brake light is 50 cm. The brake light must be installed above the rear window on the edge of the roof.

11.8. Light strips must be connected to the existing brake light circuit.

INTERIOR

- The interior of the vehicle must be clean and professional in appearance.
- All non-essential and/or loose items must be removed.
- All carpeting and/or sound deadening material must be removed.
- The inner surfaces of the door must be covered so that there are no sharp edges or protrusions that could injure the occupants of the car.

DASHBOARD

The dashboard must be either original or a copy of the original made of composite or fiber material.

GAUGES

It's prohibited to use mechanical gauges in drivers compartment (oil, fuel, water).

TYRES

- Maximum rear tire width in season 2023 is 265mm
- Front tyres are free
- Any attempt to modify tires "Grooving" or "Shaving" of tires is prohibited
- The use of traction compounds or any other substance that may alter the physical properties of the tire are prohibited.
- Eligibility of the tyres is checked during the competition at the line-up area.
- Tire warmers are prohibited.

12. DRIVERS SAFETY EQUIPMENT

HELMET

- According to FIA technical list N.25 N.33 N.49
- All occupants must wear a safety helmet during on-track sessions.

- Helmet chinstraps must be buckled, or fastened while on course.
- Cameras may not be mounted to competitor's helmets.
- Helmet homologation must be valid
- All occupants must wear a safety helmet during on-track sessions.
- Use of FHR (HANS) systems are mandatory, according to FIA Technical List no 29
- Any kind of helmet modifying is prohibited. Helmet painting must be done by certified painter. Customization must be done by following helmet manufacturer descriptions and must have issued certificate by the painter.

DRIVING SUIT

- One-piece driving suits are required and must be made of fire-resistant material and certified to FIA 2000 specs or higher, which effectively covers the body, including neck, ankles and wrists. Multi-layer driving suits are recommended. Any kind of non-manufacturer embroidery-professional, sewing, labels, prints etc. are not allowed.
- Gloves, shoes, and socks are required and must be fire-resistant material and certified to FIA 8856-2000 specs.
- Articles must be free of holes, tears or other openings except those made by the manufacturer of the equipment.
- Fire-resistant underwear is mandatory, minimum FIA 8856-2000 specs.
- (FHR)HANS support is compulsory.

SEATS

- All vehicles must have at least one seat for the driver. All the occupants' seats must have valid homologation by the FIA (8855-1999 or 8862-2009 standards), and the seats must not be modified.
- The usable life of an FIA homologated seat is 5+5 years, from the date of manufacture indicated on the seat label.
- The homologation labels must be visible and readable.
- Seat(s) must be without major damages (scratches, rips, visible wearing's etc.) .

SEAT SUPPORT

According to FIA Appendix J – ART 16.

- Seat supports shSeats must be fixed to the two square tubes (min.35x35x2.5mm) or circle tubes (min 35mmx2.5), which are welded into cross member between bodyshell lower rail and central tunnel wall. All anchorage points must be reinforced with end plates (area 40 cm², thickness 3 mm). Cross member tubes and end plates must be from same material as bodyshell. In the case of

light alloy bodyshell, end plates can be made from aluminium. Length of the end plate one side must be at least 60 mm.

- It is highly recommendable to fix seats in conformity with FIA drawing 253-65B. Seat's side anchorage points thickness must be at least 3 mm in the case of steel or 5 mm in the case of light alloy. It is prohibited to use any adapters or insets between original mountings and seat anchorage point all be of the type listed on FIA technical list No.12 (lateral, bottom, etc).

SEAT BELTS

- All safety harness must meet FIA Homologations, FIA 8853-2016 or higher and must be VALID, date on label.
- All drivers must use a six-point safety harness always on the race track (practice, qualifying and pair races).
- All Harness belts must meet FIA Homologations, FIA 8853/98 or FIA 8853-2016
- Installation according to FIA appendix J 253 – ART 6.

ARM RESTRAINTS

- Arm restraints complying with SFI Spec. 3.3 can be used in lieu of a Window Net.
- Arm restraints should be attached to the upper part of the forearm, just below the elbow. The length of the strap must be adjusted so that the hand does not go out of the rollcage area.
- Competitors may choose to use arm restraints in lieu of windows or a window net.
- Competitors with convertible vehicles must use arm restraints.

HEAD AND NECK RESTRAINTS

A Head and neck restraint certified in accordance with FIA 8858-2002 or 8858-2010 are required at all times on track during practice and competition.

EXTINGUISHERS-EXTINGUISHING SYSTEMS

- Fire extinguisher system is recommended and is mandatory
- Installation according to FIA appendix J 253 – Art 7
- All the fire extinguishers must be fitted and protected according to regulations
- All extinguishers must be adequately protected.
- Their mountings must be able to withstand a deceleration of 25 g.
- Only quick-release metal fastenings (two minimum), with metal straps, are accepted.
- Anti-torpedo tabs are required. Picture 10.
- Pipes and ends of the fire extinguishing system must be fixed with fasteners made of fire-resistant material.

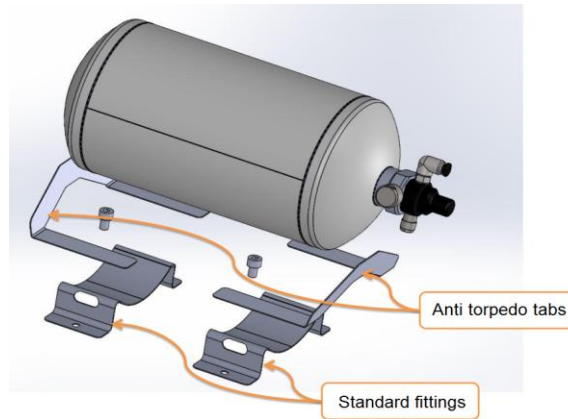

Picture 10.

13. PASSENGER

A competitor who wants to drive with a passenger in free training must have passed the corresponding one technical control. A "Ready to Drift" sticker will be marked for free practice runs with a passenger.

Special requirements for cars driving with passenger:

- Passenger's seat must be fitted
- Passenger's seat attachments and safety harness must be in compliance with requirements of the driver's seat.

Additional requirements for passenger:

- The passenger seat (fastenings and belts) must meet the same requirements as the driver's seat.
- Passenger's equipment: clothing that covers the entire body and is not flammable; helmet, must match the driver's equipment; closed shoes; long socks that cover the ankle; gloves.

FINAL WORDS

In the case of disputed or unclear situations, only the Latvia ASN Technical Commission can make changes and corrections to these technical conditions. They are approved by the LAF Technical Commission in cooperation with the Drift Commission. Changes to the rules for safety purposes are decided by the Clerk of the Course in cooperation with the drift commission and they apply immediately.

The driver is always responsible for the compliance of his car with these technical rules.

In case of disputed and/or unclear situations, contact LAF drift commission.

In all matters not defined by these technical rules, the Clerk of the Course and the head of the technical control of the competition will decide during the competitions, primarily with safety in mind. During the season, security-related problems are dealt with and decided by LAF Drift Commission.